

Panasonic[®]

**Operating Instructions
Mode d'emploi
使用說明書**

**(Household) Massage Lounger
Fauteuil vibromasseur
(家用) 電動按摩椅**

Model No. EP-MAJ7
No de modèle
型號

English	EN2
Français	FR2
繁體中文	TC2



Thank you for purchasing this Panasonic product.

Before operating this unit, please read these instructions completely and save them for future use.

Merci d'avoir acheté ce produit de Panasonic.

Avant d'utiliser cet appareil, veuillez lire ces instructions et les conserver pour une utilisation ultérieure.

感謝您購買本 Panasonic 產品。

使用本產品之前，請仔細閱讀本說明書，並妥善保存以供未來使用。



2

Searching for FAQs has been made easier.

Page **EN12**

Transport, installation and assembly

- Dimensions of main unit! (Page EN55)

Page **EN22**

What kind of courses are there?

- The back massage intensity controller display differs according to the course and action!
 (Back massage intensity control of auto course Page EN38
 Back massage intensity control of manual action)

Page **EN41**

About heat massage

- “HEAT” operating method

Page **EN53**

The sound is irritating!

- Operating sound, perception, etc.

Contents

Page

Before Use

IMPORTANT SAFETY INSTRUCTIONS . . . EN4

Part names and functions of main unit . . . EN10

Setting up the massage lounger EN12

Assembly EN14

Before sitting down EN18

How to Use

Part names and functions of the

Controller EN20

Simple use EN22

Messages

● **When you want a complete massage . . EN25**

● **When you want a concentrated massage
of a particular body part with your favorite
action EN26**

● **Air stretching and Sole massage EN28**

Memory Course EN31

Adjusting the intensity EN36

After completing the massage EN43

Moving/Maintenance

Moving the unit EN44

Cleaning and maintenance EN45

Important Notes



Q&A EN46

Troubleshooting EN51

Error display EN52

Sounds and sensations of the unit EN53

Specifications EN54

 DANGER	Denotes a potential hazard that will result in serious injury or death.
 WARNING	Denotes a potential hazard that could result in serious injury or death.
 CAUTION	Denotes a hazard that could result in minor injury or property damage.

IMPORTANT SAFETY INSTRUCTIONS

Basic precautions should always be followed when using an electrical unit, including the following. Please ensure that you read all instructions before using the Household Massage Lounger.

DANGER

To reduce the risk of electric shock:

1. Always unplug this appliance from the electrical outlet immediately after using and before cleaning.

WARNING

To reduce the risk of burns, fire, electric shock, or injury to persons:

1. The unit should never be left unattended when plugged in. Always unplug the unit when not in use.
2. Close supervision is necessary when this appliance is used by, on, or near children, invalids, or disabled persons. Keep children away from the legrest.
3. Only use the unit for the purpose described in these instructions.
4. Do not use any accessories other than those recommended by the manufacturer.
5. Always return the seat to the upright position and make sure the legrest is completely retracted. Be careful that nothing is obstructing the legrest while retracting.
6. Never operate the unit if it has a damaged power cord or plug. Return the unit to the nearest authorized service center if it is not working properly, if it has been dropped or damaged, or if it has been immersed in water.
7. Keep power cords away from heated surfaces. Do not carry the unit by the power cord.
8. Never block the air openings during operation and make sure that all air openings are kept free of lint and hair, etc. Do not drop or insert anything into any of the openings of the unit.
9. Do not use the unit on top of heating appliances, such as electric carpets, etc. Do not operate the unit under blanket or pillow. Excessive heating can occur and cause fire, electric shock, or injury to persons.
10. Do not use the unit outdoors.
11. Do not use or operate where aerosol spray products are being used or where oxygen is being administered.
12. Connect this unit to a properly grounded outlet only. See Grounding instructions.
13. Use heated surfaces carefully. May cause serious burns. Do not use over insensitve skin areas or in the presence of poor circulation. The unattended use of heat by children or incapacitated persons may be dangerous.
14. Do not use the unit in close proximity to loose clothing or jewelry.
15. Keep long hair away from the unit while in use.
16. After each massage, slide the power switch on the backside of unit body to the "off" position, turn the lock switch to the "lock" position and then remove the lock switch key and power plug.

SAVE THESE INSTRUCTIONS

GROUNDING INSTRUCTIONS

This unit must be grounded. If it should malfunction or breakdown, grounding provides a path of least resistance for electric current to reduce the risk of electric shock. This unit is equipped with a cord having an equipment-grounding conductor and a grounding plug. The plug must be plugged into an appropriate outlet that is properly installed and grounded in accordance with all local codes and ordinances.

DANGER

Improper connection of the equipment-grounding conductor can result in a risk of electric shock. Check with a qualified electrician or serviceman if you are in doubt as to whether the product is properly grounded. Do not modify the plug provided with the product – if it will not fit the outlet, have a proper outlet installed by a qualified electrician. This product is for use on a nominal 120-volt circuit and has a grounding plug that looks like the plug illustrated in Figure A. Make sure that the product is connected to an outlet having the same configuration as the plug. No adapter should be used with this product.

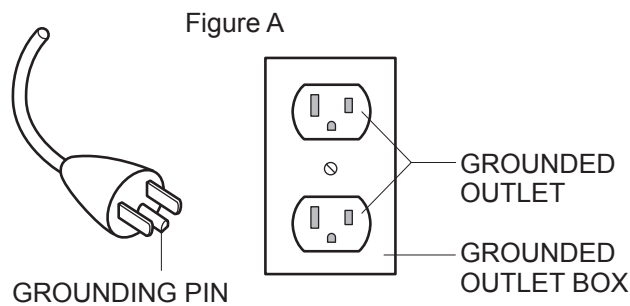

- This unit is not intended for use by persons (including children) with reduced physical sensory or mental capabilities, or lack of experience and knowledge, unless they have been given supervision or instruction concerning use of the unit by a person responsible for their safety.
- Children should be supervised to ensure that they do not play with the unit.

IMPORTANT SAFETY INSTRUCTIONS (Continued)



Denotes a specific operating procedure that must not be performed.



Denotes a specific operating procedure that must be performed.

WARNING

Symptoms



- The following persons should not use this unit:

- (1) Persons who are prohibited from receiving massages by a physician (e.g.: due to thrombosis, severe aneurism, acute varicose veins, any type of dermatitis and skin infections (including inflammation of the hypodermis), etc.)
- (2) Persons suffering from osteoporosis, spine fracture, sprain or acute pain such as a pulled or torn muscle
- (3) Persons who have a pacemaker, defibrillator, or other personal medical devices prone to electronic interference
- (4) Pregnant women and women who have just given birth
- (5) Persons with symptoms of acute low back pain, herniated disk, spondylolisthesis, spinal stenosis, degenerative lumbar spondylosis
- (6) Persons who have abnormalities or curvature of the spine

- The following persons should not use the lower back/hip massage or pelvis stretch.

- (1) Those with symptoms of acute inflammation around the hip area, acute hip pain, piriformis muscle syndrome or sciatic neuralgia
- (2) Those suffering from osteoarthritis of the hip and bad hip joint
- (3) Those who feel pain, numbness, lethargy in the hip and legs during use (Doing so may worsen the symptoms.)

- The unit is not to be used by people who cannot move or communicate on their own.



- Persons with any of the conditions listed below or who are undergoing medical treatment should consult with their physicians before using the unit.

- (1) Persons who have a malignant tumor
- (2) Persons suffering from heart disease
- (3) Persons who have a loss of heat sensation
- (4) Persons who have sensory abnormalities due to a severe peripheral circulatory disturbance such as diabetes mellitus
- (5) Persons who have a wound where the massager operates
- (6) Persons whose body temperature is over 38 °C (100.4 °F) (who have a fever) (E.g.: When a person has acute inflammation symptoms (fatigued, chills, blood pressure fluctuations, etc.) or when debilitated)
- (7) Persons who require bed rest or who are in poor physical shape
- (8) Persons other than those listed above who feel unwell

- If you begin to feel unwell during use or if you do not feel effects of the massage lounger, stop use immediately and consult a physician.

(Failure to do so may cause an accident, injury or become unwell.)

If a malfunction or breakdown occurs



- If a malfunction or breakdown occurs, stop using the chair immediately and unplug the power plug from the wall socket. (Failure to do so may result in smoke/fire or electric shock.)

<Examples of malfunctions/breakdowns>



- Does not start when pressing .
- The power supply goes on and off when the power cord is moved.
- Burning smells or abnormal sounds occurring during operation.
- The unit becomes deformed or unusually hot.

→ Contact an authorized service center immediately for inspection/repairs.



Take note of the following points as well

-  Absolutely do not modify. Furthermore, do not attempt to disassemble or repair the unit yourself. (Doing so may cause fire, or may cause the unit to function abnormally resulting in injury.)

When in use

-  When massaging the neck area, be careful of the movement of the massage heads and avoid massaging the throat area and excessively strong massage action.
 - Do not sit on the backrest or armrests.
 - This unit should not be used by children. Also, do not allow children to play on the unit, or to climb on the seat, backrest or armrests.
 - Do not use the massage lounger while holding children.
 - Do not push your hands, elbows, arms or feet against the fabric covering the moving parts of the backrest during use. (Doing so may cause an accident or injury.)
 - When "HEAT" are used, do not let the massage heads touch the same place for a long time. (Low temperature burns* may occur.)
 - * Burns may occur at relatively low temperatures (40 °C (104 °F) to 60 °C (140 °F)) when in contact with the same area of skin for long periods of time, even if you do not feel heat or pain.
-  Always check the fabric covering the backrest or legrest movable parts has not been ripped before using the unit. Please also check other areas to ensure the fabric has not been ripped.
-  No matter how small the rip, if you find one then immediately stop using the unit, unplug the power plug and have the unit repaired at an authorized service center. (Failure to do so may result in injuries or electric shocks.)
 - Start using a gentle Swedish massage.
 - Do not massage for more than 30 minutes a day.
 - Do not massage any one part of your body for more than 5 minutes at a time. (Doing so may result in adverse effect or injury.)
 - Confirm that the shoulder position is correct when body scanning (Page EN24) is performed. If it is not properly aligned, use the POSITION button to adjust the shoulder height, or stop the massage and perform the body scanning again (when using auto course, manual operation).
 - Make sure there are no persons or pets around the unit (front, back, underneath or sides of the unit) before using it for massaging or moving the backrest or legrest. (Failure to do so may cause an accident or injury.)

Power plug, power cord etc

-  Do not do anything that may damage the power cord or power plug.
 - Do not scratch, modify, use near a heater, excessively bend, twist, pull, place heavy objects on top of, or bundle the cord or plug. (Doing so may cause electric shock, burning or fire due to a short circuit.)
 - Contact the nearest authorized service center for repairs to the power cord or power plug.
 - Do not insert or unplug the power plug with wet hands. (Doing so may cause electric shock.)
-  Always use sockets and wiring devices at the correct rated value.
 - Use AC 120 V. (Cannot be used overseas, nor with a transformer.)
 - Always insert the power plug fully into the socket. (Failure to do so may result in electric shock or fire due to overheating.)
 - Dust the power plug on a regular basis.
 - Remove dust using a dry cloth. (Failure to do so may result in fire, due to damp shorting the insulation.)
 - When unplugging the power plug, hold the plug itself and do not pull on the power cord. (Failure to do so may cause electric shock, burning or fire due to a short circuit.)

IMPORTANT SAFETY INSTRUCTIONS (Continued)

CAUTION

To avoid risk of injury.

Symptoms



- Persons who are otherwise healthy but have any of the conditions listed below should consult with their physicians before using the unit.

- (1) Persons whose muscles have deteriorated due to age or weight loss
- (2) Persons with symptoms of lower back and hip pain caused by the bones and muscles, organs and nerves
- (3) Persons who suffer bruises or sprains easily
- (4) Persons who suffer from severe motion sickness
- (5) Persons who have undergone heart or internal surgery in the past

(Failure to do so may adversely affect health.)

- The unit has a heated surface. Persons insensitive to heat must be careful when using the unit.
- If symptoms such as rashes, reddening, itching, etc. occur as a result of using this unit, stop using the unit and consult a physician. (Failure to do so may cause an accident or adversely affect health.)

Installation and movement



- Do not drag or push the unit in an installed state.
- Do not move the unit using the castors on the flooring. (Doing so may damage the flooring.)
- Do not move with a person on it. (Doing so may result in falls, causing an accident or injury.)
- Do not hold the sole massage section when moving the unit. (It may slide in movement, causing injury.)
- Do not use in damp or humid places such as a bathroom. (Doing so may cause electric shock.)



- Use only on a horizontal surface. (Failure to do so may result in a falling accident.)
- Place a mat or other such covering on the floor when moving the unit using the castors. (Unit may damage the flooring.)
- When moving the unit on its castors, remove any obstacles from around the unit, move the backrest to the fully upright position, lift the legrest to a position below the waist (less than 80 cm (31.5 in.) from the floor) and move the unit slowly. (Page EN44) (Otherwise the unit may fall and cause injury.)

Power supply



- To ensure safety, connect the unit to a properly grounded outlet. (Page EN13)
 - Failure to do so may cause an accident or discharge. (Failure to do so may cause electric shock.)
- Always unplug the power plug from the wall socket when cleaning the unit or removing the cover. (Failure to do so may cause an electric shock or injury.)
- Always unplug the power plug from the wall socket when not using. (Since dust and humidity deteriorates insulation, which may result in fire due to electrical fault.)

Before and during use

- Do not use the massage heads on your head, stomach or bare skin. Also, do not place your hands or feet between the massage heads.
 - Do not place your knees between the leg & sole massage section.
 - Do not fall asleep while using the unit. Do not use the unit after drinking alcohol.
 - Do not stand, jump on, or place objects on the seat until the air is completely extracted after the air action.
(Doing so may cause an accident or injury.)
 - Do not insert your hands, fingers, feet or head into the following spaces:
 - (1) Between the backrest and seat or armrest
 - (2) Between the legrest and seat or armrest
 - (3) Between the seat and armrest
 - (4) Between the back cover and leg cover
 - (5) Back of the legrest
 - Do not unplug the power plug or turn the power switch "off" during massage.
 - Do not use the sole massage in a standing position.
(Doing so may cause injury.)
 - Do not sit on, stand on, or place objects on the legrest when the legrest is not completely lowered.
(Doing so may cause the edge of the legrest to rotate or the unit to tip over, resulting in an accident or injury.)
 - Do not use at the same time as another medical device.
(Doing so may cause an accident or deteriorated health.)
- !
- Check that the massage heads are in the retracted position.
 - Be sure that all operations have stopped before getting off the unit during a massage.
(Failure to do so cause an accident or injury.)
 - Check that there is no foreign matter between the parts of the unit before sitting down.
 - Check that there are no foreign objects stuck in the backrest, legrest or hand & arm massage section.
 (Hands, feet or small objects may become trapped, resulting in an accident or injury.)
 - Avoid wearing anything hard on your head like a hair accessory, etc. when using the unit.
 - Do not massage with any hard objects in your trouser pockets.
 - Remove hard objects such as false fingernails, wristwatches or rings when massaging hands or arms.
(Doing so may cause injury.)
 - Do not drop anything from your pockets, etc. into the gaps of the device. (You could lose them.)

Take note of the following points as well

- Do not allow children to use the controller holder fixing screw.
(Doing so may cause an accident such as a child swallowing the screw.)
- Do not spill water on the unit or controller.
(Doing so may cause electric shock, ignition or fire due to a short circuit.)
- Store the lock switch key out of the reach of children.
(Failure to do so may cause an accident such as the child swallowing the key.)
- In the event of a power outage, unplug the power plug immediately.
(Failure to do so may cause an accident or injury when the power supply returns.)
- If you have not used the unit for a while, carefully read the operating instructions again and check that the unit is operating normally before use.
(Failure to do so may result in breakage or injury.)

Part names and functions of main unit

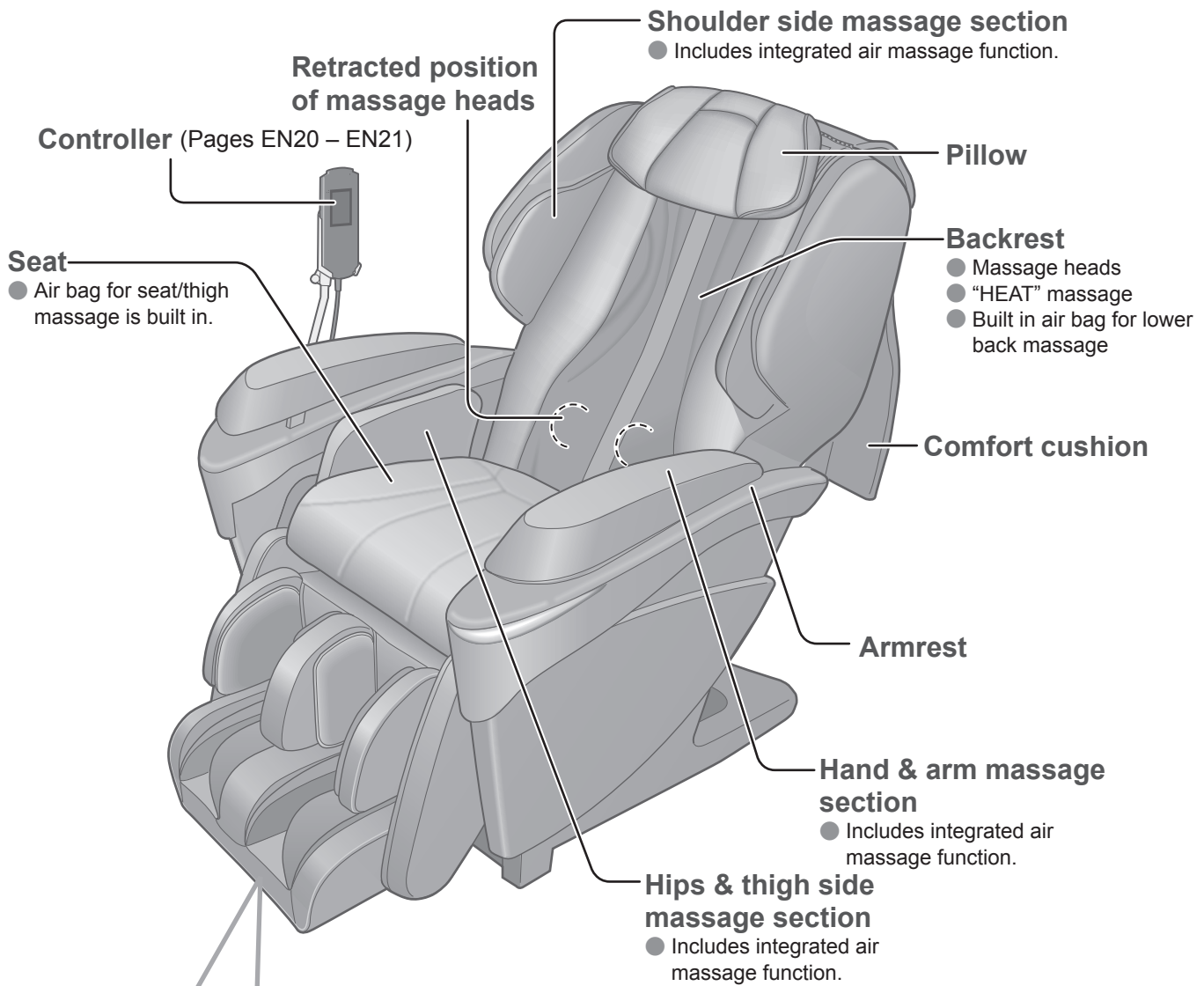

Legrest-Leg & Sole Massage Section

- Massage by sole roller.
- Includes air massage function.
- Position can be adjusted by sliding sole massage section.

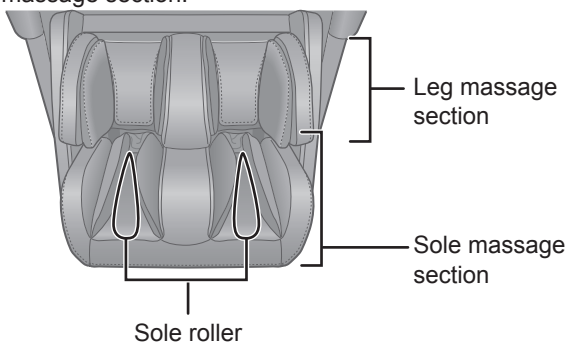

■ Sole roller

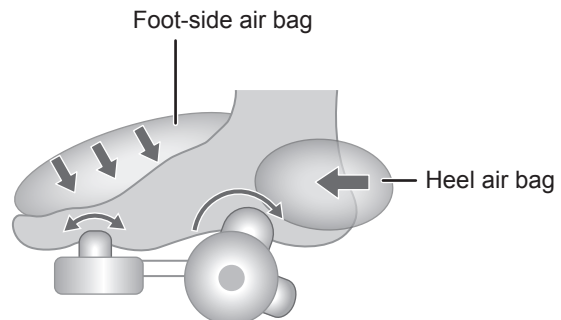

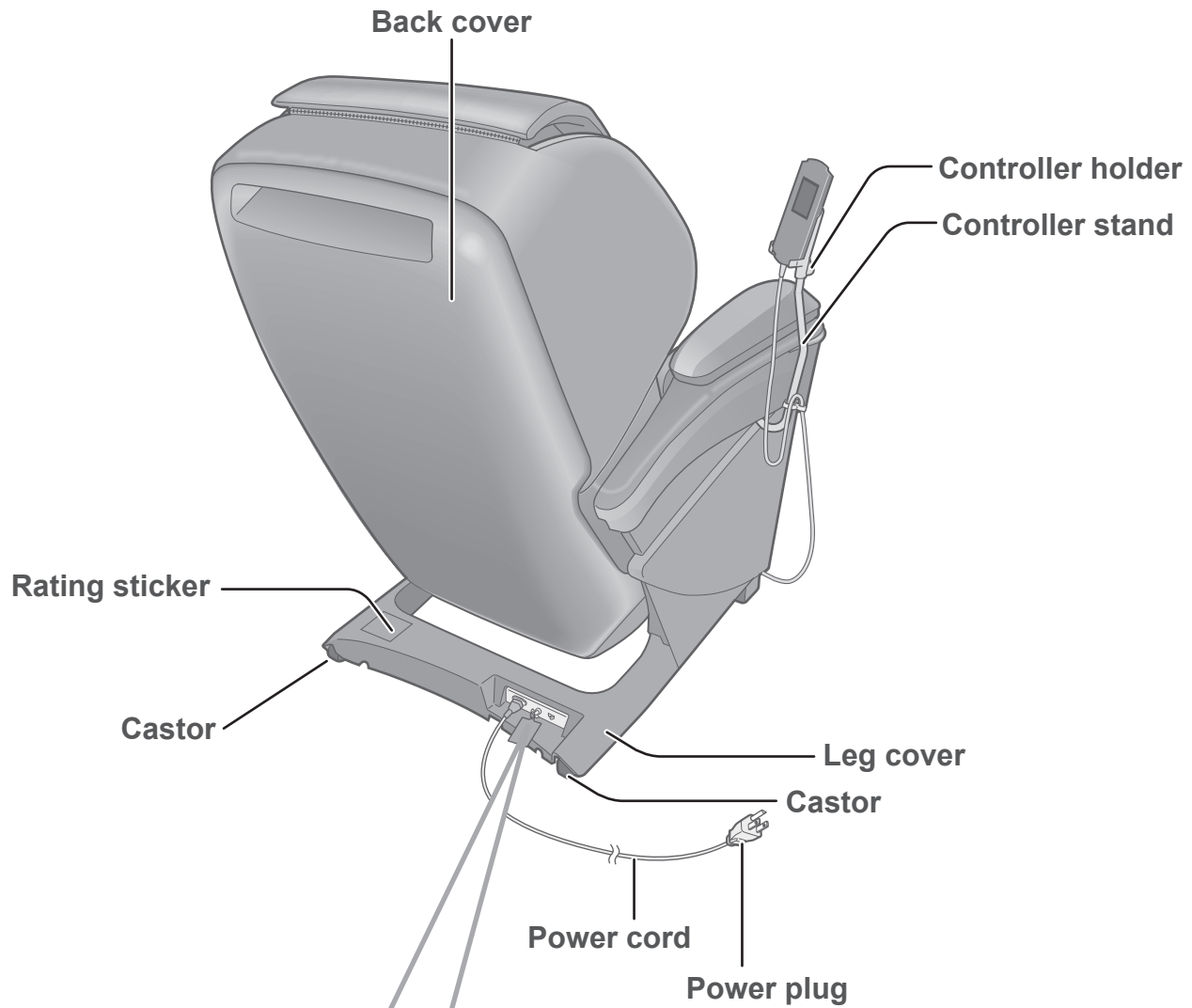

Power switch section

lock switch

power

open

lock

off

on

Lock switch

Power switch

Lock switch key

Lock switch key tag



- For preventing children from swallowing it by accident.

● Lock switch is set to "open" and power switch is set to "on" prior to leaving the factory.

Setting up the massage lounger

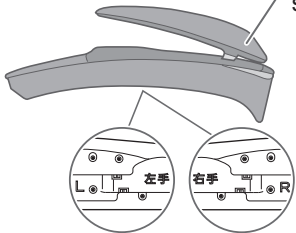
1) Checking the accessories

- **Armrests (Right/Left)** The holes in the fabric at the back of the hand & arm massage section are due to the manufacturing process and are not a fault.
 

Right/Left indication (armrest back)
- **Comfort cushion**

- **Pillow**

- **Power cord**

2) Where to use the unit

Ensure there is adequate space to recline.

- Dimensions required for installation (see page EN55 for the detailed dimensions of the main unit)

Approximate Dimension: Height 115 cm (45.3 in.) × Width 90 cm (35.4 in.) × Depth* 220 cm (86.6 in.)

* The actual depth of the main unit is 200 cm (78.7 in.) but the required depth is stated as 220 cm (86.6 in.) so as to install it at least 10 cm (3.9 in.) away from the wall etc. at the front and back.

- Do not expose the massage lounger to direct sunlight or high temperatures, such as in front of heating sources. This can cause discoloration or hardening of the synthetic leather.

3) Installing



- ① **The unit must be carried by two or more persons.**
 - Since the unit is heavy, be careful to avoid back injuries.

Unit weight	Approx. 87 kg (191.8 lbs)
--------------------	------------------------------

- ② **Watch your step carefully and put down the unit slowly.**

Lay out a mat etc.
 Since the unit may damage the flooring, it is recommended to place the unit on a mat.
When placing a mat under the unit, the size of the mat should be sufficient (at least 120 cm × 70 cm (47.2 in. × 27.6 in.)) to cover the areas where the unit touches and where the legrest could touch the floor.

Hold the legrest by the sides



Hold the legrest with your hands until it has been set on the floor completely. If you release the legrest too soon, it will spring back to the initial position.

Do not hold the foot part!

The sole massage section might slide, and injuries may occur.

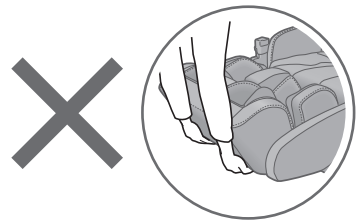

● **Controller stand**

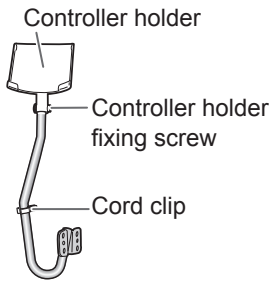

● **Lock switch key (1 pc.)**

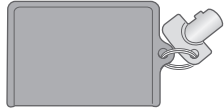

This is initially inserted in the lock switch of the power switch section prior to leaving the factory.

● **Allen key (1 pc.)**

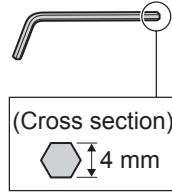

● **Attachment screws (M6 × 13) Black (4 pcs.)**



● **(M6 × 29) Silver (2 pcs.)**

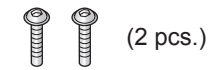

4) Connect the power cord to the unit

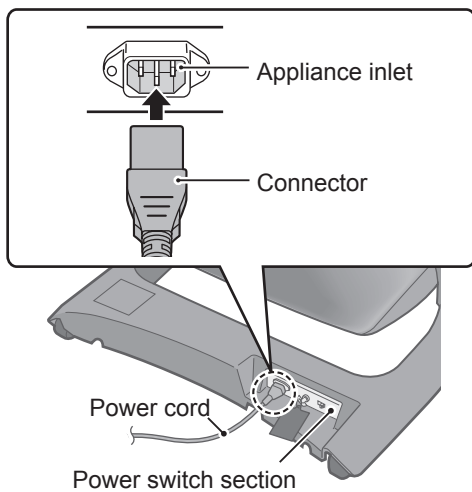

- ① Check for dirt and damage on appliance inlet of the power switch section and the connector of the power cord.
- ② Insert the connector into the appliance inlet.
- ③ Be sure to push the connector in all the way.

GROUNDING INSTRUCTIONS

- This unit must be grounded. If it should malfunction or breakdown, grounding provides a path of least resistance for electric current to reduce the risk of electric shock.
- This unit is equipped with a cord having an equipment-grounding conductor and a grounding plug. The plug must be plugged into an appropriate outlet that is properly installed and grounded in accordance with all local codes and ordinances.

5) Turn on the power and raise the backrest to the upright position.

- ① **Insert the power plug into the power outlet.**
 - Always be sure to insert into an AC 120 V plug.
- ② **Confirm the lock switch key is set to the “open” position.**
- ③ **Confirm the power switch is set to the “on” position.**
- ④ **Press on the controller twice.**
 - Press once, and then press again approx. 1 second later. Backrest will rise automatically.

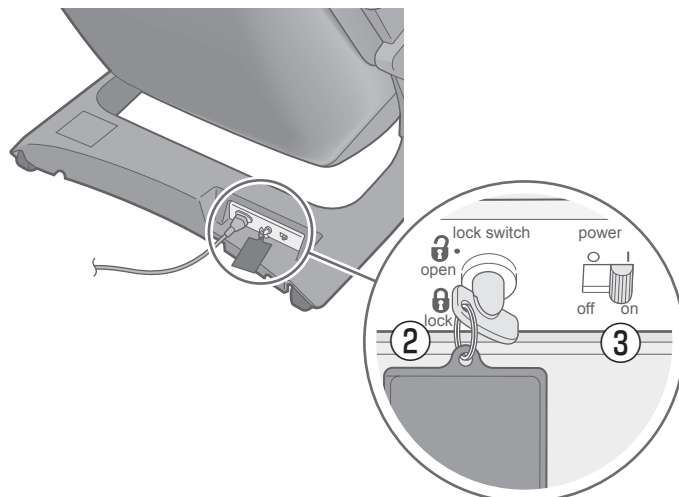
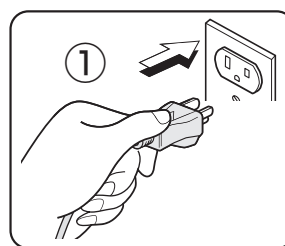

Assembly

1 Attaching the controller stand

The controller stand can be attached on either the left or right side.

<When attaching on the right armrest>

- ① Align the 2 prongs of the side panel with the holes of the controller stand.

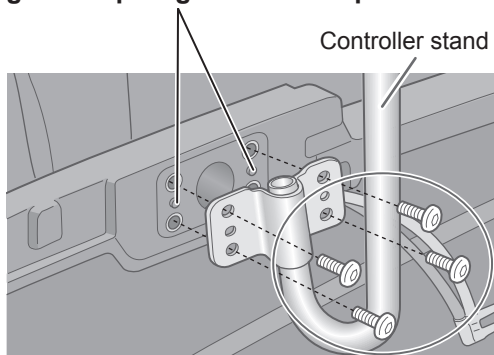

- ② Fasten the controller stand with the attachment screws (4 positions)

- Use this screw
Attachment screws (M6 × 13) × 4 pcs.
(Black)

How to tighten the screws

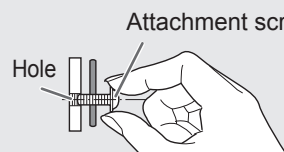

- Tighten the 4 screws lightly using your fingers. (Make the screws level with the holes.)

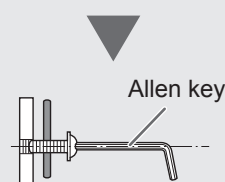

- Tighten firmly with the allen key.
- Screw may be damaged if you tighten the screw inserted into the hole crookedly using an allen key.

If the controller stand is attached on the left hand side, pass the controller cord through the left hand side. (Page EN17)

2 Fasten the armrest

- ① Insert the armrest into the unit.
 - “R” (right side) and “L” (left side) are indicated at the back of the armrest.
 - Insert the armrest from the top aligning the ▲ marks on the side of the armrest.
 - Be careful to avoid pinching your fingers and air plugs.

- ② Slide the armrest toward the back while pushing it downward.

- ③ Fasten the armrest with the attachment screws. (One for each side)

- Use this screw
Attachment screws (M6 × 29) × 2 pcs. (Silver)

How to tighten the screws

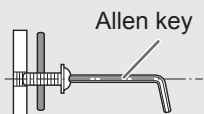

- Put an attachment screw on the edge of the allen key and tighten the screw horizontally to the hole.
- Screw may be damaged if you tighten the screw inserted into the hole crookedly using an allen key.

- ④ Attach the left hand side in the same way.

<Attaching the right armrest>

Front

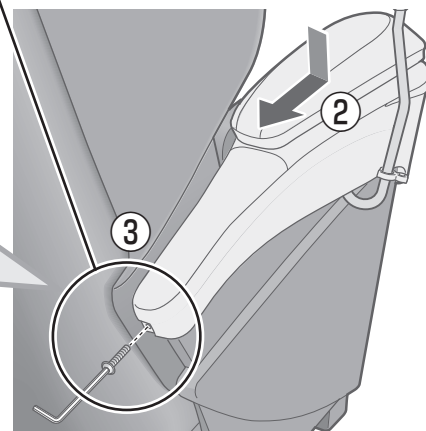
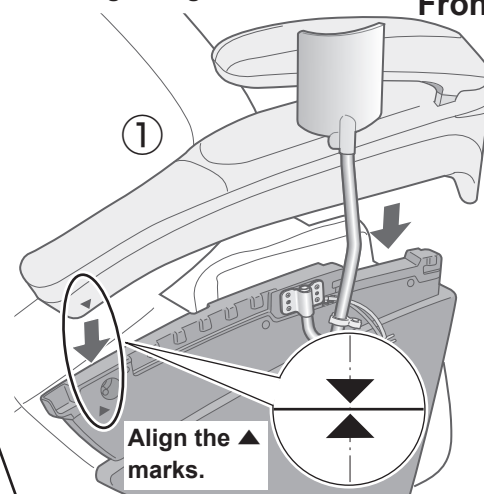

3 Inserting the air plug

- ① Insert the air plug into the air plug jack on the armrest with your fingers until it clicks into position.

<View from bottom>

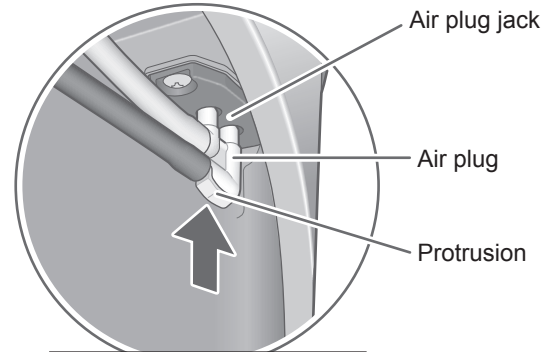

Press until the protrusion clicks into place.

- Arm massage will not operate unless the air plugs are inserted securely.

- ② Insert the left side in the same way.

4 Attaching the controller to the controller holder

- ① Insert the controller at an angle to the bottom of the controller holder.

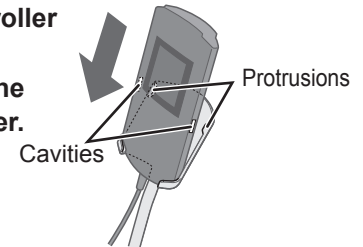

- ② Insert the controller until the two protrusions on the controller holder click into the cavities on both sides of the controller.

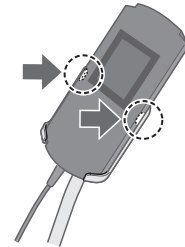

Lift up the controller to remove.

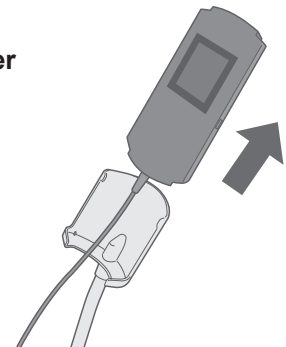

- Fasten the controller cord using the cord clip. Fasten so the cable under the cord clip will not sag too much (because of the risk of tripping over the cord).

